

PHYSICAL SETTING PHYSICS

Tuesday, June 25, 2024 — 9:15 a.m. to 12:15 p.m., only

The possession or use of any communications device is strictly prohibited when taking this examination. If you have or use any communications device, no matter how briefly, your examination will be invalidated and no score will be calculated for you.

Answer all questions in all parts of this examination according to the directions provided in the examination booklet.

A separate answer sheet for Part A and Part B–1 has been provided to you. Follow the instructions from the proctor for completing the student information on your answer sheet. Record your answers to the Part A and Part B–1 multiple-choice questions on this separate answer sheet. Record your answers for the questions in Part B–2 and Part C in your separate answer booklet. Be sure to fill in the heading on the front of your answer booklet.

All answers in your answer booklet should be written in pen, except for graphs and drawings, which should be done in pencil. You may use scrap paper to work out the answers to the questions, but be sure to record all your answers on your separate answer sheet or in your answer booklet as directed.

When you have completed the examination, you must sign the statement printed on your separate answer sheet, indicating that you had no unlawful knowledge of the questions or answers prior to the examination and that you have neither given nor received assistance in answering any of the questions during the examination. Your answer sheet and answer booklet cannot be accepted if you fail to sign this declaration.

Notice . . .

A scientific or graphing calculator, a centimeter ruler, a protractor, and a copy of the *2006 Edition Reference Tables for Physical Setting/Physics*, which you may need to answer some questions in this examination, must be available for your use while taking this examination.

DO NOT OPEN THIS EXAMINATION BOOKLET UNTIL THE SIGNAL IS GIVEN.

Part A

Answer all questions in this part.

Directions (1–35): For *each* statement or question, choose the word or expression that, of those given, best completes the statement or answers the question. Some questions may require the use of the *2006 Edition Reference Tables for Physical Setting/Physics*. Record your answers on your separate answer sheet.

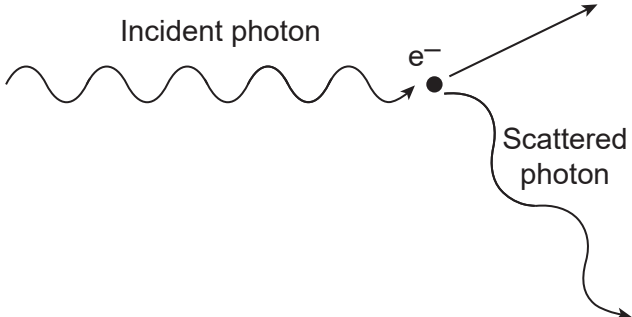
- Which quantity is a vector?
 - electric field
 - electric potential difference
 - electric charge
 - electric power
- What is the magnitude of the eastward component of the velocity of an airplane flying at 612 kilometers per hour in a direction 40.0° north of east?
 - 393 km/h
 - 469 km/h
 - 799 km/h
 - 952 km/h
- A car, initially traveling at 25 meters per second, is uniformly brought to rest as the brakes are applied over a distance of 40. meters. The magnitude of the average acceleration of the car while braking is
 - 0.31 m/s^2
 - 0.63 m/s^2
 - 7.8 m/s^2
 - 16 m/s^2
- A brick starts from rest and falls freely from the top of a building to the ground. As the brick falls, its acceleration
 - increases and its speed increases
 - increases and its speed is constant
 - is constant and its speed increases
 - is constant and its speed is constant
- Which object has the greatest inertia?
 - a 0.10-kg baseball traveling at 30. m/s
 - a 70-kg sprinter traveling at 10. m/s
 - a 1000-kg car traveling at 50. m/s
 - a 2000-kg truck traveling at 20. m/s
- An unbalanced force is always necessary to
 - keep a body at rest
 - keep a body moving with constant velocity
 - change the speed of a body
 - change the position of a body
- Space probes launched from Earth send information back to Earth from space in the form of
 - mechanical waves
 - sound waves
 - longitudinal waves
 - electromagnetic waves
- A ball is thrown from level ground at an angle of 55° above the horizontal and lands on level ground. Neglecting friction, if the ball is thrown again at the same angle but with a larger initial speed, the ball will travel
 - higher and the same distance horizontally
 - to the same maximum height and farther horizontally
 - both higher and farther horizontally
 - to the same maximum height and the same distance horizontally
- A photon collides with an electron, as represented in the diagram below.
 - loses energy to the electron
 - gains momentum from the electron
 - loses some speed
 - generates a magnetic field

- 10 What is the weight of a 60.0-kilogram student on the surface of Earth?
- (1) 0.164 N (3) 60.0 N
 (2) 6.12 N (4) 589 N
- 11 A 120-newton box is pulled by a 48-newton horizontal force across a horizontal surface at constant velocity. The coefficient of kinetic friction between the box and the horizontal surface is
- (1) 0.041 (3) 0.67
 (2) 0.40 (4) 2.5
- 12 Box A has a mass of 10. kilograms and is at rest on a shelf that is 1.5 meters above the floor. Box B has a mass of 20. kilograms and is at rest on a shelf that is 3.0 meters above the floor. Compared to box A, box B has a gravitational potential energy relative to the floor that is
- (1) one fourth as great (3) twice as great
 (2) the same (4) four times as great
- 13 A 0.10-kilogram yo-yo is whirled at the end of a length of string in a horizontal circular path of radius 0.80 meter at a speed of 6.0 meters per second. The magnitude of the centripetal acceleration of the yo-yo is
- (1) 4.5 m/s² (3) 23 m/s²
 (2) 7.5 m/s² (4) 45 m/s²
- 14 A 4.0-kilogram mass is initially at rest on a horizontal, frictionless surface. A constant 2.0-newton force to the east is applied to the mass for a 5.0-second interval. As a result of this action, the mass acquires a
- (1) velocity of 10. m/s, east
 (2) velocity of 10. m/s, west
 (3) momentum of 10. kg•m/s, east
 (4) momentum of 10. kg•m/s, west
- 15 A motor lifts a 1.2×10^4 -newton elevator 9.0 meters in 15 seconds. The minimum power output of the motor is
- (1) 8.0×10^2 W (3) 1.0×10^5 W
 (2) 7.2×10^3 W (4) 1.6×10^6 W
- 16 A train blows its horn, which emits a uniform sound as the train approaches a stationary observer. The observer hears a sound that has a
- (1) lower frequency than the emitted sound and is decreasing in amplitude
 (2) lower frequency than the emitted sound and is increasing in amplitude
 (3) higher frequency than the emitted sound and is decreasing in amplitude
 (4) higher frequency than the emitted sound and is increasing in amplitude
- 17 A wood block is pulled at constant velocity across a horizontal wood floor. Which type of energy increases in this block-floor system as the block moves?
- (1) gravitational potential (3) mechanical
 (2) kinetic (4) thermal
- 18 A total energy of 5.0 joules is used to move an electron from position A to position B in a uniform electric field. What is the potential difference between positions A and B?
- (1) 3.1×10^{19} V (3) 3.2×10^{-20} V
 (2) 8.0×10^{-19} V (4) 3.1×10^{18} V
- 19 A 0.14-kilogram lacrosse ball, traveling west at 17 meters per second, is brought to rest with a 0.21-kilogram lacrosse stick. If the force applied by the lacrosse stick on the ball is 220 newtons east, the force applied by the ball on the stick is
- (1) 150 N east (3) 220 N east
 (2) 150 N west (4) 220 N west
- 20 Four wires are tested for electrical conductivity. All the wires have the same length and the same cross-sectional area, but are made of different metals. Which wire has the highest conductivity at 20°C?
- (1) aluminum (3) gold
 (2) copper (4) silver
- 21 The angle of incidence for a ray of light striking a plane mirror is 20°. What is the angle between the incident ray and the reflected ray?
- (1) 20° (3) 70°
 (2) 40° (4) 90°

- 22 As shown in the diagram below, mass M slides across a level, frictionless surface with speed v_i . The mass strikes a spring at position A , causing the spring to compress. When the mass is at position B , it is moving at a slower speed, v_f .

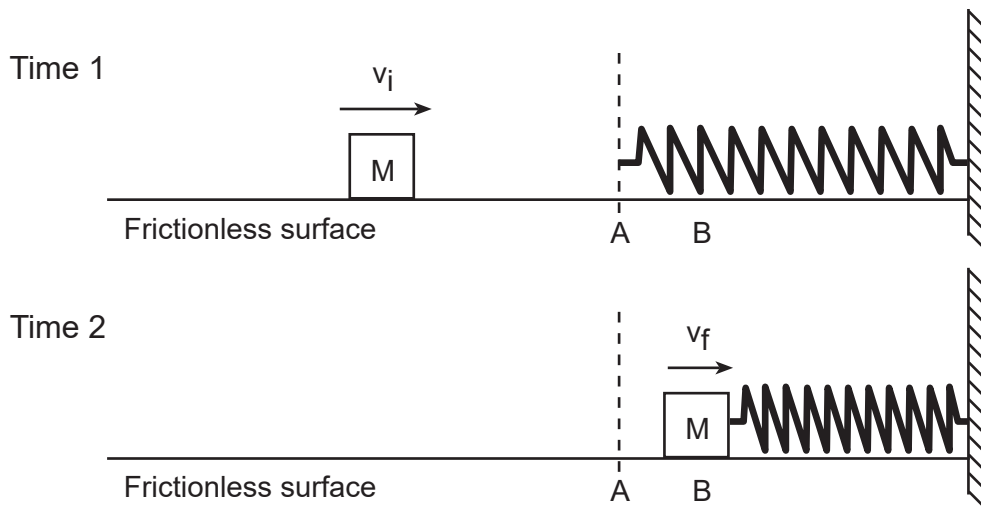

Which statement best describes the energy conversion as the mass moves from position A to position B ?

- (1) Some of mass M 's kinetic energy is converted to elastic potential energy.
 - (2) All of mass M 's kinetic energy is converted to elastic potential energy.
 - (3) Some of mass M 's kinetic energy is converted to gravitational potential energy.
 - (4) All of mass M 's kinetic energy is converted to internal energy.
- 23 The diagram below shows a magnetic compass placed between unlike magnetic poles.

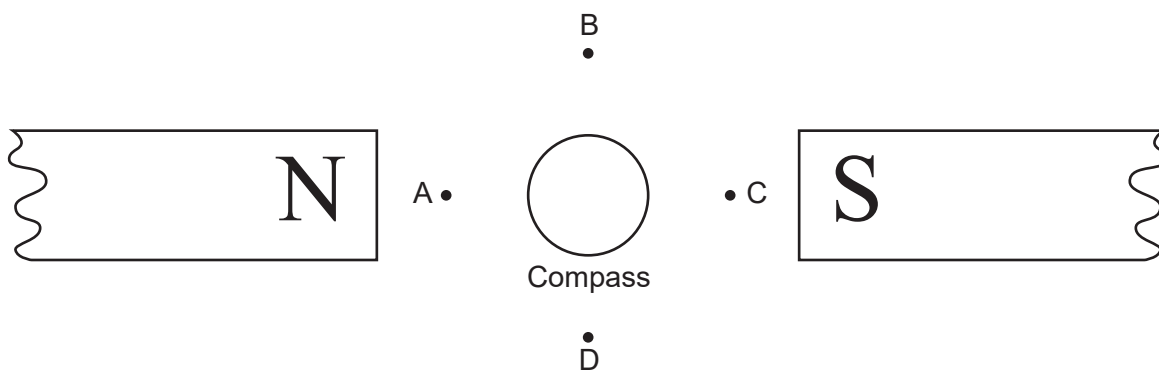

The north pole of the compass needle will point toward

- (1) A
- (2) B
- (3) C
- (4) D

24 Which circuit diagram contains a lamp that will *not* have current passing through it until switch S is closed?

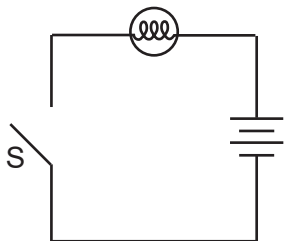

(1)

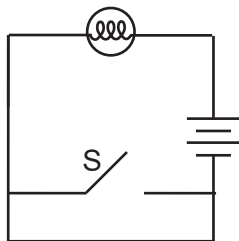

(3)

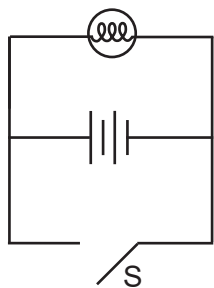

(2)

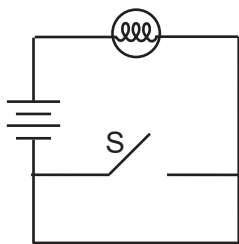

(4)

25 The diagram below represents an electric circuit.

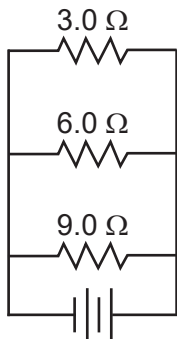

The equivalent resistance of the circuit is

- (1) 1.6Ω (3) 6.0Ω
 (2) 2.0Ω (4) 18Ω

26 An object is thrown vertically upward with an initial velocity of 9.81 meters per second. What is the maximum height reached by the object? [Neglect friction.]

- (1) 1.00 m (3) 9.81 m
 (2) 4.91 m (4) 19.6 m

27 Which type of photon has the *least* amount of energy?

- (1) ultraviolet (3) infrared
 (2) visible light (4) radio

28 A 7.5-kilogram object moving at 20. meters per second strikes a 60.-kilogram object initially at rest on a horizontal, frictionless surface. The two objects stick together and move off at a speed of

- (1) 0.33 m/s (3) 2.5 m/s
 (2) 2.2 m/s (4) 18 m/s

29 How is the electrostatic force between two positive charges affected as the charges are brought closer together?

- (1) The force of attraction between them increases.
 (2) The force of repulsion between them increases.
 (3) The force of attraction between them decreases.
 (4) The force of repulsion between them decreases.

30 What is one difference between magnetic forces and gravitational forces?

- (1) Magnetic forces are always attractive, whereas gravitational forces are always repulsive.
 (2) Magnetic forces are always repulsive, whereas gravitational forces are always attractive.
 (3) Magnetic forces may be attractive or repulsive, whereas gravitational forces are always attractive.
 (4) Magnetic forces may be attractive or repulsive, whereas gravitational forces are always repulsive.

- 31 A sound wave passes through an opening in a brick wall as represented in the diagram below.

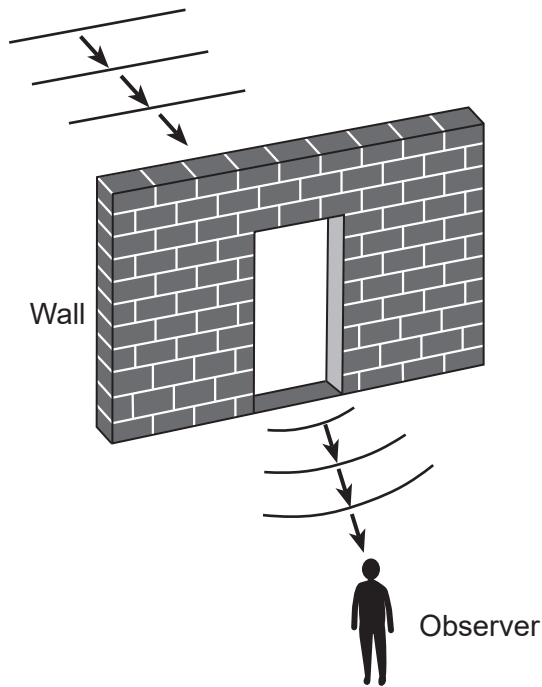

An observer standing behind the wall is able to hear the sound. This spreading out of the sound wave as it passes through the opening is an example of

- | | |
|------------------|-----------------|
| (1) interference | (3) refraction |
| (2) reflection | (4) diffraction |

- 32 A sound wave is emitted by a vibrating tuning fork. What is transferred as the sound wave travels to a student's ear?

- (1) mass, only
- (2) energy, only
- (3) both mass and energy
- (4) neither mass nor energy

- 33 An electric current passing through a copper wire at constant temperature would result in

- (1) an increase in the resistivity of the wire
- (2) a decrease in the resistivity of the wire
- (3) the emission of protons from the wire
- (4) the production of a magnetic field around the wire

- 34 The velocity of an object in uniform circular motion has a

- (1) constant magnitude and changing direction
- (2) constant magnitude and constant direction
- (3) changing magnitude and constant direction
- (4) changing magnitude and changing direction

- 35 Tuning fork A starts to vibrate at 320 hertz when it is held near tuning fork B, already vibrating at 320 hertz. Which phenomenon is exemplified by the action of tuning fork A?

- | | |
|------------------------|-----------------|
| (1) the Doppler effect | (3) diffraction |
| (2) resonance | (4) refraction |

Part B-1

Answer all questions in this part.

Directions (36–50): For each statement or question, choose the word or expression that, of those given, best completes the statement or answers the question. Some questions may require the use of the 2006 Edition Reference Tables for Physical Setting/Physics. Record your answers on your separate answer sheet.

36 A light ray with a frequency of 5.09×10^{14} hertz has a wavelength of 2.44×10^{-7} meter in diamond. The wavelength of this light ray in sodium chloride is

- (1) 1.55×10^{-7} m
(2) 2.44×10^{-7} m
(3) 3.83×10^{-7} m
(4) 5.89×10^{-7} m

37 The diagram below shows resistors R_1 , R_2 , and R_3 connected to a 12-volt source.

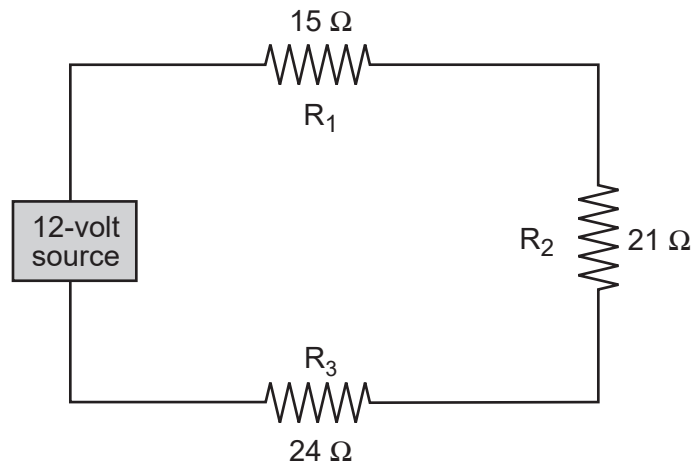

The current flowing through resistor R_3 is

- (1) 5.0 A
(2) 2.0 A
(3) 0.50 A
(4) 0.20 A

38 A charge of 25 coulombs moves past a point in a circuit in 2.5 seconds. What is the current at that point in the circuit?

- (1) 0.10 A
(2) 10. A
(3) 50. A
(4) 63 A

39 Which statement describes an object with constant kinetic energy?

- (1) A car accelerates along a straight road.
(2) A runner decreases her speed along a curved path.
(3) A bicycle travels around a curve at constant speed.
(4) A sled travels down a frictionless, steep, straight hill.

40 Which phrase describes a box in equilibrium?

- (1) box in an elevator slowing down as it rises vertically
- (2) box at rest on a stationary table
- (3) box sliding down a frictionless ramp
- (4) box in free fall

41 Quarks may combine to produce a meson of charge

- (1) $-\frac{1}{3}e$
- (2) $+2e$
- (3) $+\frac{1}{3}e$
- (4) $0e$

42 The diagram below shows waves A and B as they travel through a region in the same medium.

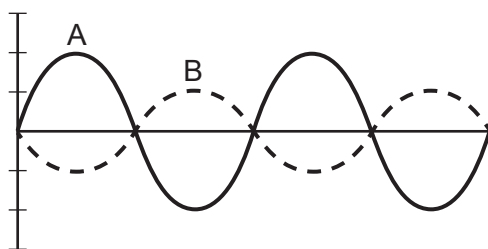

Which wave best represents the superposition of waves A and B?

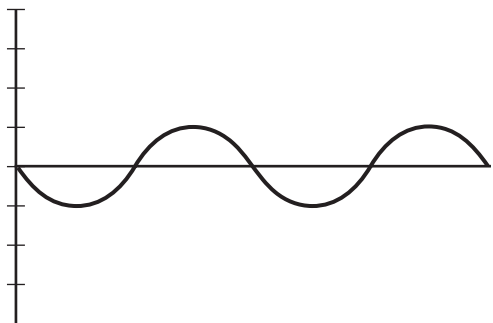

(1)

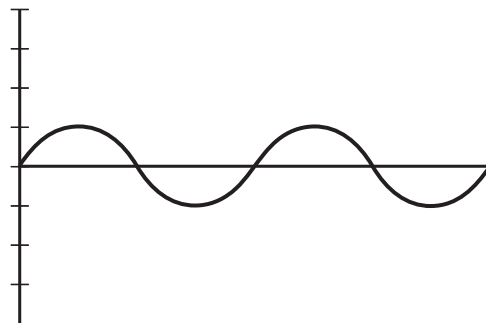

(3)



(2)

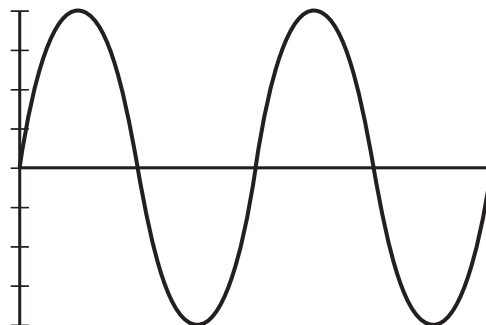

(4)

43 The diagrams below show the direction of wave travel and the direction of medium particle vibration for different waves. Which diagram best represents the characteristics of a sound wave?

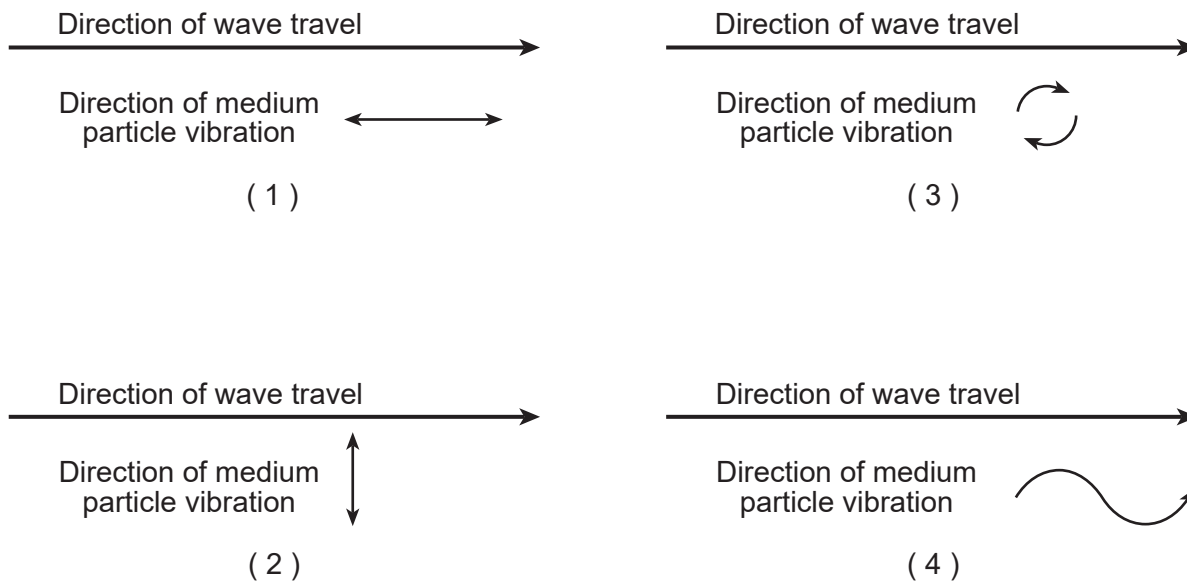

44 In a sample of gas, many excited hydrogen atoms are in the $n = 4$ energy level. What is the maximum number of different photon energies that can be emitted by these atoms as they return to the ground state?

- (1) 6
- (2) 5
- (3) 3
- (4) 4

Base your answers to questions 45 and 46 on the information below and on your knowledge of physics.

Two students did an experiment to measure the acceleration of a freely falling object. One student dropped an object from rest. The other student measured the distance fallen by the object and the corresponding time of fall. The data for the dropped object are shown below.

distance fallen by object = 2.4 meters
time of fall = 0.71 second

45 Based on the data for the dropped object, the experimental value calculated for the object's acceleration is

- (1) 11 m/s^2
- (2) 9.5 m/s^2
- (3) 6.8 m/s^2
- (4) 4.8 m/s^2

46 The ideal value for the acceleration differs from the one obtained experimentally by the students. What is one possible cause of this discrepancy?

- (1) The object was given some initial horizontal velocity.
- (2) The force of gravity was much stronger outside the building than inside.
- (3) Motion formulas should not be used in an experimental setting.
- (4) There may have been errors in the measurement of distance and/or time.

47 Which graph represents the motion of an object falling freely from rest near the surface of the Moon?

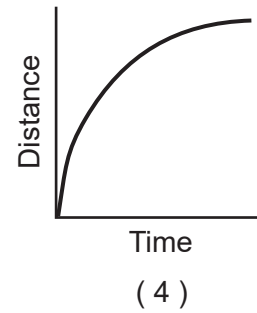
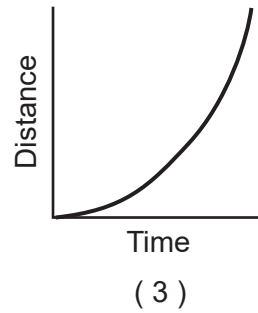
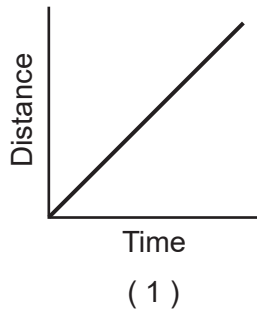

48 The diagrams below represent the initial velocities, v_i , of four identical projectiles launched from level ground at various angles above the horizontal. Which projectile will have the longest time of flight? [Neglect friction.]

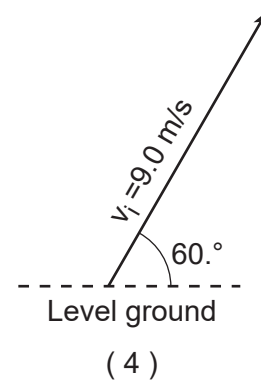
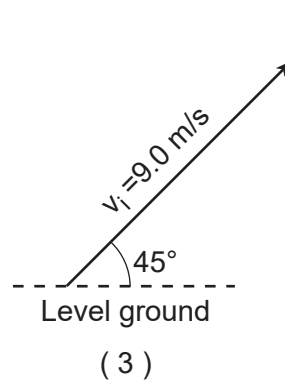
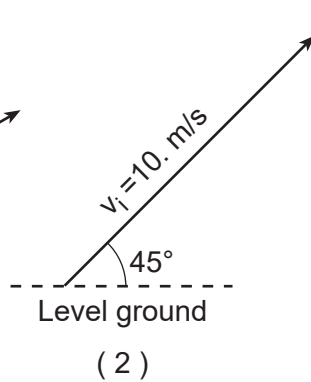
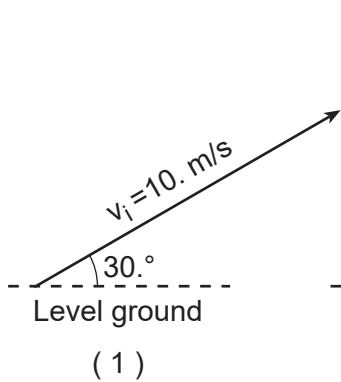

49 Four forces act on a crate on a level floor, as shown in the diagram below.

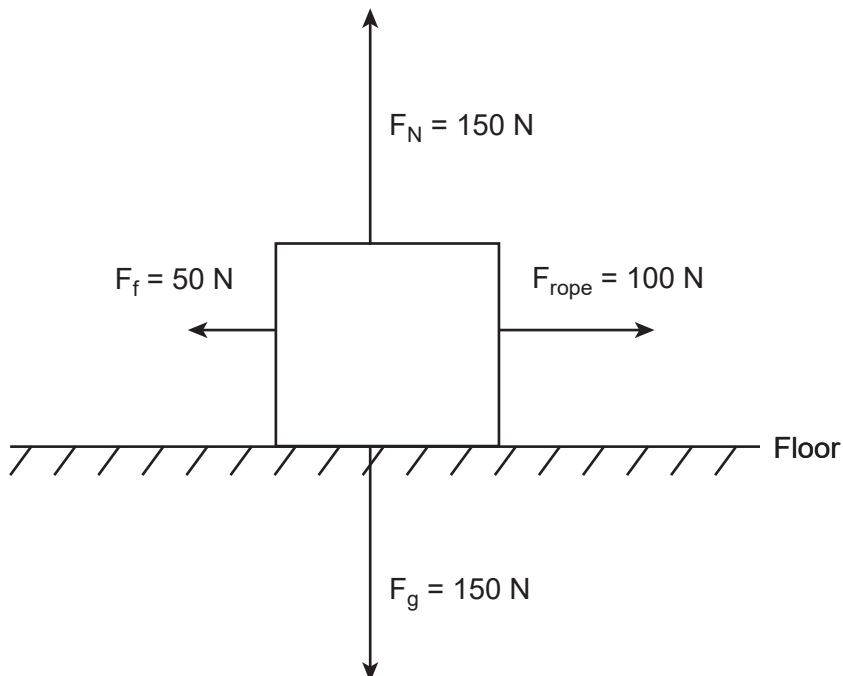

At the instant shown, the crate is

- (1) accelerating to the right
- (2) accelerating to the left
- (3) moving at constant velocity to the right
- (4) remaining at rest

50 The graph below represents the relationship between the potential energy stored in a spring, PE_s , and the elongation of the spring, x .

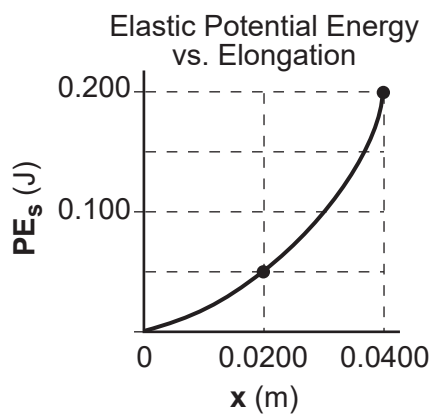

The value of the spring constant is

- (1) 5.00 N/m
- (2) 10.0 N/m
- (3) 125 N/m
- (4) 250. N/m

Part B–2

Answer all questions in this part.

Directions (51–65): Record your answers in the spaces provided in your answer booklet. Some questions may require the use of the *2006 Edition Reference Tables for Physical Setting/Physics*.

51–52 Planet Nede has a mass of 6.50×10^{23} kilograms and a radius of 2.96×10^6 meters. The magnitude of the gravitational force of attraction exerted on a 5.00-kilogram object by planet Nede is 7.15 newtons when the object is located at a position 5.50×10^6 meters from the center of Nede. Calculate the gravitational field strength of planet Nede at the position of the object. [Show all work, including the equation and substitution with units.] [2]

53–54 As shown in the diagram below, a toy car, initially traveling at 1.0 meter per second, uniformly accelerates to a speed of 4.0 meters per second as it travels down a 5.0-meter-long slope.

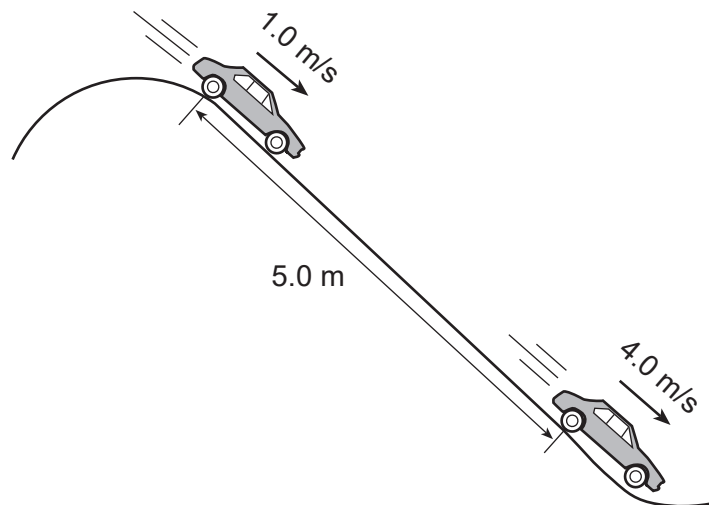

(Not drawn to scale)

Calculate the time required for the toy car to travel the 5.0 meters from the top of the slope to the bottom. [Show all work, including the equation and substitution with units.] [2]

55–56 Calculate the resistance of an incandescent lightbulb that operates at 20. watts of power when connected to a 12-volt battery. [Show all work, including the equation and substitution with units.] [2]

Base your answers to questions 57 through 59 on the information and graph below and on your knowledge of physics.

The motion of a car traveling along a straight road is represented in the graph below.

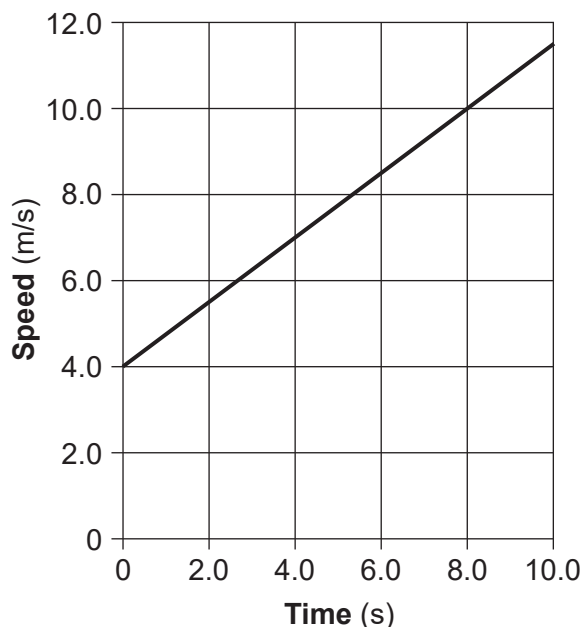

57 Determine the average speed of the car from $t = 0$ to $t = 8.0$ seconds. [1]

58–59 Calculate the magnitude of the acceleration of the car from $t = 0$ to $t = 8.0$ seconds. [Show all work, including the equation and substitution with units.] [2]

60 A light ray is traveling through a transparent medium at a speed of 1.75×10^8 meters per second. Determine the absolute index of refraction of this medium for this light ray. [1]

61 As shown in the diagram below, a ray of light traveling through medium X is incident upon the surface of medium Y. The absolute index of refraction of medium Y is greater than the absolute index of refraction of medium X.

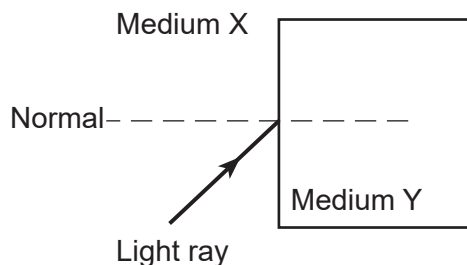

On the diagram *in your answer booklet*, use a straightedge to draw a ray that could represent the path of the light in medium Y. [1]

62–63 A tungsten wire has a cross-sectional area of 5.03×10^{-7} meter squared and has a resistance of 1.21×10^{-2} ohm when operated at 20°C . Calculate the length of this wire. [Show all work, including the equation and substitution with units.] [2]

64–65 As shown in the diagram below, a block is hanging motionless from a vertical spring, having caused the spring to elongate from its unstretched length of 0.200 meter to a length of 0.500 meter. The spring has a spring constant of 250. newtons per meter.

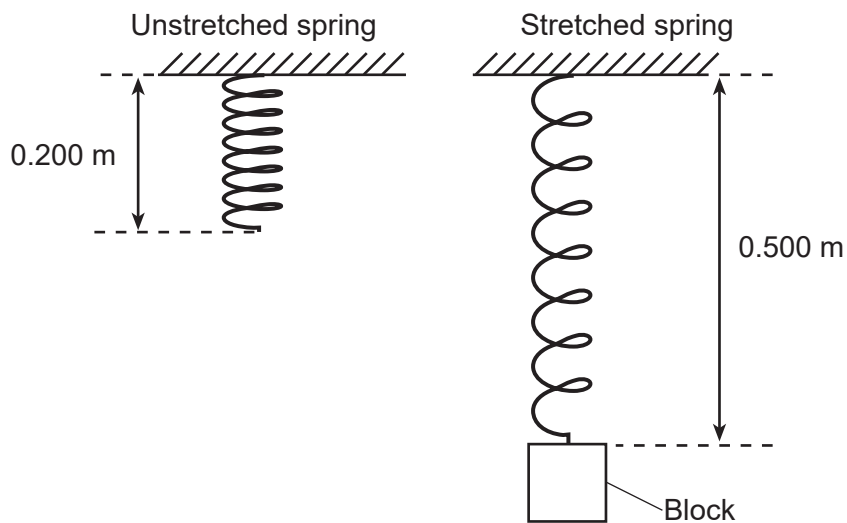

Calculate the magnitude of the force exerted by the block on the spring. [Show all work, including the equation and substitution with units.] [2]

Part C

Answer all questions in this part.

Directions (66–85): Record your answers in the spaces provided in your answer booklet. Some questions may require the use of the *2006 Edition Reference Tables for Physical Setting/Physics*.

Base your answers to questions 66 through 70 on the information and data table below and on your knowledge of physics.

In an experiment, a resistor is connected to a source of varying potential difference. A voltmeter and an ammeter are included in the circuit so that the current can be measured at different potential difference settings. The data table below shows the potential differences and currents measured.

Data Table	
Potential Difference (V)	Current (A)
0.0	0.00
2.0	0.26
3.0	0.35
5.0	0.63
8.0	0.98

Directions (66–67): Using the information in the data table, construct a graph on the grid in your answer booklet following the directions below.

66 Plot the data points for current versus potential difference. [1]

67 Draw the line of best fit. [1]

68–69 Calculate the slope of the line. [Show all work, including the equation and substitution with units.] [2]

70 Determine the resistance of the resistor. [1]

Base your answers to questions 71 through 75 on the information and diagram below and on your knowledge of physics.

An alpha particle with a charge of +2 elementary charges is moving toward two oppositely charged parallel plates, as shown in the diagram below. The magnitude of the electric field strength between the plates is 5.0×10^4 newtons per coulomb.

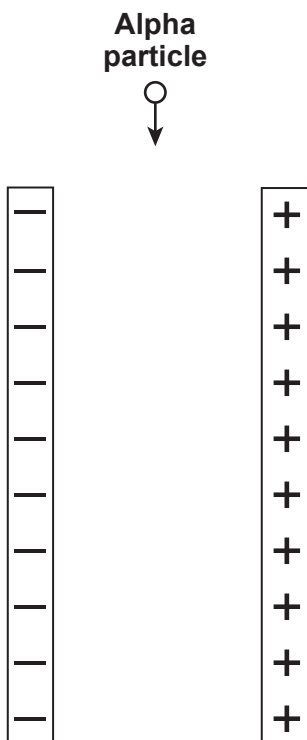

- 71 Determine the magnitude of the charge of an alpha particle in coulombs. [1]
- 72 On the diagram *in your answer booklet*, draw *at least three* field lines to show the direction of the electric field in the space between the charged plates. [1]
- 73 What is the direction of the electrostatic force exerted on the alpha particle as it passes between the plates? [1]
- 74–75 Calculate the magnitude of the electrostatic force exerted on the alpha particle by the electric field as the alpha particle passes through the electric field. [Show all work, including the equation and substitution with units.] [2]
-

Base your answers to questions 76 through 80 on the information below and on your knowledge of physics.

Two students investigate transverse waves using a long, stretched spring. One student holds one end of the spring stationary, while the other student produces 12 waves every 4.0 seconds. The waves have a uniform amplitude of 0.20 meter and the distance between two adjacent crests is 0.40 meter.

76–77 On the diagram *in your answer booklet*, draw *at least one* complete wave produced in the spring. [2]

78 Determine the frequency of the waves. [1]

79–80 Calculate the speed of the waves. [Show all work, including the equation and substitution with units.] [2]

Base your answers to questions 81 through 85 on the information below and on your knowledge of physics.

Alpha particles are stable decay products of many nuclear disintegrations. An alpha particle consists of two protons and two neutrons and has a mass of 6.644×10^{-27} kilogram. When the individual masses of two protons and two neutrons are added, the sum is 6.695×10^{-27} kilogram. The difference between the mass of an alpha particle and the total mass of its four individual component particles is called the mass defect.

81 Determine the mass defect in kilograms when two protons and two neutrons combine to form an alpha particle. [1]

82–83 Calculate the total amount of energy in joules that would result from the complete conversion of this mass defect to energy. [Show all work, including the equation and substitution with units.] [2]

84 Determine the total amount of energy that would result from the complete conversion of this mass defect to energy in megaelectronvolts (MeV). [1]

85 What fundamental interaction is primarily responsible for holding protons and neutrons together in an alpha particle? [1]
